

अंतर-विश्वविद्यालय त्वरक केंद्र

INTER-UNIVERSITY ACCELERATOR CENTRE

(विश्वविद्यालय अनुदान आयोग का स्वायत्त निकाय)

(An Autonomous Centre of UGC)

अरुणा आसफ अली मार्ग, नई दिल्ली-110067

Aruna Asaf Ali Marg, New Delhi - 110067

ई-निविदा आमंत्रण सूचना/ NOTICE INVITING E-TENDER

निविदा संख्या: आईयूएसी/एनआईटी/ 23/SGK/2023-24

दिनांक: 25/01/2024

Tender Number: IUAC/NIT/23/SGK/2023-24

Dated: 25/01/2024

अंतर-विश्वविद्यालय त्वरक केंद्र (आई.यू.ए.सी.) पात्र/अनुभवी पार्टियों से दो बोली प्रणाली नामतः तकनीकी और वित्तीय बोली के तहत ई-प्रोक्योरमेंट पोर्टल के माध्यम से निदेशक, अंतर-विश्वविद्यालय त्वरक केंद्र, नई दिल्ली की ओर से "अनुलग्नक के अनुसार यू एच वी कंपेटेबल डबल स्लिट असेम्बली विथ कंट्रोलर " की आपूर्ति के लिए ऑनलाइन बोलियां आमंत्रित करता है।

Inter - University Accelerator Centre (IUAC) invites online bids on behalf of the Director IUAC, New Delhi through e-procurement Portal under two bid system, viz., Technical and Financial bids, from eligible / experienced parties for the supply of "**Dual Channel Low Noise High Voltage Fast Switch as per Annexure A**".

निविदा दस्तावेज, सेंट्रल पब्लिक प्रोक्योरमेंट (सीपीपी) पोर्टल <https://eprocure.gov.in/eprocure/app> से निःशुल्क में डाउनलोड किए जा सकते हैं। इच्छुक बोलीदाता, जिन्होंने ई-प्रोक्योरमेंट पोर्टल में नामांकन/पंजीकरण नहीं किया है, उन्हें भाग लेने से पहले <https://eprocure.gov.in/eprocure/app> वेबसाइट के माध्यम से नामांकन/पंजीकरण करना होगा। बोलियां केवल <https://eprocure.gov.in/eprocure/app> वेबसाइट पर ऑनलाइन जमा करनी होंगी। निविदाकारों/ठेकेदारों/बोलीदाताओं को सलाह दी जाती है कि वे ई-प्रोक्योरमेंट पोर्टल में दिए गए निदेशों का पालन करें। बोली दस्तावेजों को 100 डी.पी.आई. में ब्लैक एंड व्हाइट स्कैन करें, जो स्कैन किए गए दस्तावेजों के आकार को कम करने में मदद करता है।

Tender Documents may be downloaded from Central Public Procurement (CPP) Portal free of cost <https://eprocure.gov.in/eprocure/app>. Aspiring Bidders who have not enrolled / registered in e-procurement portal should enroll / register before participating through the website <https://eprocure.gov.in/eprocure/app>. Bids should be submitted online only at website: <https://eprocure.gov.in/eprocure/app>. Tenderers / Contractors / Bidders are advised to follow the instructions provided in the e-procurement portal. Bid documents may be scanned with 100 dpi with black and white option which helps in reducing size of the scanned documents.

केवल ई-प्रोक्योरमेंट पोर्टल के माध्यम से प्राप्त बोलियों को ही खोला जाएगा। जो बोलियाँ उत्पादों/वस्तुओं के कार्य/आपूर्ति के वांछित प्रयोजनों को संपूर्ण रूप से पूर्ण करने में अक्षम होंगी, उन बोलियों को अस्वीकार कर दिया जाएगा और केवल पूर्ण बोलियों पर विचार किया जाएगा। अंतर-विश्वविद्यालय त्वरक केंद्र के पास बिना कोई कारण बताए किसी भी/सभी निविदाओं को आंशिक/पूर्ण रूप से स्वीकार/अस्वीकार करने का अधिकार सुरक्षित है और इस संबंध में आईयूएसी का निर्णय सभी बोलीदाताओं के लिए बाध्यकारी होगा।

Only bids received through e-procurement portal will be considered for opening. Bids not covering full scope of work/supply of the products/goods will be rejected and only complete bids will be considered. IUAC reserves the right to accept / reject any / all tenders in part / full without assigning any reasons whatsoever, and the decision of IUAC in this regard will be binding on all the bidders.

ई.एम.डी. का भुगतान करने के लिए बोलीदाता को "ऑनलाइन" भुगतान विकल्प का चयन करना होगा, जो <https://services.sabpaisa.in/pages/iuac.html> लिंक पर जाकर लागू होगा। बयाना राशि ऑनलाइन भुगतान के रूप में होगी और इसे बोली खोलने से पहले जमा किया जाना चाहिए। एम.एस.एम.ई./एन.एस.आई.सी. में पंजीकृत बोलीदाताओं को ई.एम.डी. के भुगतान से छूट दी गई है। तथापि, उन्हें बोली सुरक्षा घोषणा प्रपत्र जमा करना होगा। एम.एस.एम.ई./एन.एस.आई.सी.(निविदा की गई वस्तु/कार्य के लिए पंजीकृत इकाई) से पंजीकृत निविदाकारों को तकनीकी बोली के साथ वैध पंजीकरण प्रमाणपत्र की प्रति <https://eprocure.gov.in/eprocure/app> वेबसाइट पर अपलोड करनी होगी।

Bidder has to select the payment option as "online" to pay the EMD as applicable by going to the link <https://services.sabpaisa.in/pages/iuac.html>. The Earnest Money Deposit shall be in the form of online payment and it should be deposited before the bid opening. Bidders registered with MSME/NSIC are exempted from payments of EMD. Tenderers registered with MSME/NSIC (the unit being registered for the item/work tendered) are required to upload copy of valid registration certificate in the website <https://eprocure.gov.in/eprocure/app> along with technical bid.

बोलीदाताओं को इस बात को विशेष ध्यान में रखने की सलाह दी जाती है कि वे अनिवार्य रूप से उपलब्ध कराए गए प्रारूप में ही अपनी वित्तीय बोलियां जमा करें और कोई अन्य प्रारूप स्वीकार्य नहीं होगा। यदि मूल्य बोली निविदा दस्तावेज के साथ मानक .XLS BOQ प्रारूप के रूप में दी गई है, तो इसे ही डाउनलोड करना होगा और प्रारूप को संशोधित किए बिना ऑनलाइन भरना और जमा करना होगा। यदि बोलीदाता द्वारा BOQ फाइल को संशोधित पाया जाता है, तो बोली को अस्वीकार कर दिया जाएगा।

Bidders are advised to note that they should necessarily submit their financial bids in the format provided and no other format is acceptable. If the price bid has been given as a standard .XLS BOQ Format with the tender document, then the same is to be downloaded and to be filled and submitted online without modifying the format. **If the BOQ file is found to be modified by the bidder, the bid will be rejected.**

उपरोक्त निविदा के संबंध में कोई भी शुद्धिपत्र/संशोधन केवल <https://eprocure.gov.in> और www.iuac.res.in वेबसाइट पर जारी किया जाएगा। बोलीदाता, अपनी बोली जमा करने से पहले निविदा दस्तावेज से संबंधित, प्रकाशित होने वाले किसी भी शुद्धिपत्र की जानकारी रखें। निदेशक, अंतर-विश्वविद्यालय त्वरक केंद्र के पास बिना कोई कारण बताए किसी भी/सभी निविदाओं को आंशिक/पूर्ण रूप से स्वीकार/अस्वीकार करने का अधिकार सुरक्षित है।

Any Corrigendum / Amendments in respect of above tender shall be issued on website <https://eprocure.gov.in> and www.iuac.res.in only. Bidders should take into account any corrigendum published on the tender document before submitting their bids. The Director, IUAC reserves the right to accept/reject any/all tenders in part/full without assigning any reasons thereof.

INSTRUCTIONS TO BIDDERS

REGISTRATION PROCESS ON CPP PORTAL FOR ONLINE BIDDING

- 1** Bidders are required to enroll on the e-Procurement module of the Central Public Procurement Portal (URL: <https://eprocure.gov.in/eprocure/app>) by clicking on the link “**Online Bidder Enrolment**” on the CPP Portal which is free of charge.
Bidder who registered already may skip the registration process and login to site through their user ID/Password
- 2** As part of the enrolment process, the bidders will be required to choose a unique username and assign a password for their accounts.
- 3** Bidders are advised to register their valid email address and mobile numbers as part of the registration process. These would be used for any communication from the CPP Portal.
- 4** Upon enrolment, the bidders will be required to register their valid Digital Signature Certificate (Class II or Class III Certificates with signing key usage) issued by any Certifying Authority recognized by CCA India (e.g. Sify / nCode / eMudhra/ Nic etc.), with their profile.
- 5** Only one valid DSC should be registered by a bidder. Please note that the bidders are responsible to ensure that they do not lend their DSCs to others which may lead to misuse.
- 6** Bidder then logs in to the site through the secured log-in by entering their user ID / password and the password of the DSC / e-Token.

SEARCHING FOR TENDER DOCUMENTS

1. There are various search options built in the CPP Portal, to facilitate bidders to search active tenders by several parameters. These parameters could include Tender ID, Organization Name, Location, Date, Value, etc. There is also an option of advanced search for tenders, wherein the bidders may combine a number of search parameters such as Organization Name, Form of Contract, Location, Date, Other keywords etc. to search for a tender published on the CPP Portal.
2. Once the bidders have selected the tenders they are interested in, they may download the required documents / tender schedules. These tenders can be moved to the respective ‘My Tenders’ folder. This would enable the CPP Portal to intimate the bidders through SMS / e-mail in case there is any corrigendum issued to the tender document.
3. The bidder should make a note of the unique Tender ID assigned to each tender; in case they want to obtain any clarification / help from the Helpdesk.

PREPARATION OF BIDS

1. Please go through the tender advertisement and the tender document carefully to understand the documents required to be submitted as part of the bid. Please note the number of covers in which the bid documents have to be submitted, the number of documents - including the names and content of each of the document that need to be submitted. Any deviations from these may lead to rejection of the bid.
2. Bidder, in advance, should get ready the bid documents to be submitted as indicated in the tender document / schedule and generally, they can be in PDF / XLS / RAR / DWF/JPG formats. Bid documents may be scanned with 100 dpi with black and white option which helps in reducing size of the scanned document.
3. To avoid the time and effort required in uploading the same set of standard documents which are required

to be submitted as a part of every bid, a provision of uploading such standard documents (e.g. PAN card copy, GST Certificate etc.) has been provided to the bidders. Bidders can use “My Space” or “Other Important Documents” area available to them to upload such documents. These documents may be directly submitted from the “My Space” area while submitting a bid, and need not be uploaded again and again. This will lead to a reduction in the time required for bid submission process.

Note: Bidder should take into account any corrigendum published on the tender document before submitting their bids.

INSTRUCTION FOR SUBMISSION OF BIDS

1. The tender shall be submitted online in two parts, viz., Technical bid and Financial bid (also referred as price bid).
2. The offers submitted by hand/Post/Fax/email shall not be considered. No correspondence will be entertained in this matter.
3. All the pages of bid being submitted must be sequentially numbered by the bidder irrespective of nature and content of the documents before uploading.
4. The bidders are required to submit soft copies of their bids electronically on the CPP Portal, using valid Digital Signature Certificates. The instructions given below are meant to assist the bidders in registering on the CPP Portal, prepare their bids in accordance with the requirements and submitting their bids online on the CPP Portal.
5. Bidder should log into the site well in advance for bid submission so that they can upload the bid in time i.e. on or before the bid submission time. Bidder will be responsible for any delay due to other issues.
6. The bidder has to digitally sign and upload the required bid documents one by one as indicated in the tender document.
7. Bidders are requested to note that they should necessarily submit their financial (price Bid) bids in the format provided and no other format is acceptable. If the price bid has been given as a standard BOQ format with the tender document, then the same is to be downloaded and to be filled by all the bidders. Bidders are required to download the BOQ file, open it and complete the white coloured (unprotected) cells with their respective financial quotes and other details (such as name of the bidder). No other cells should be changed. Once the details have been completed, the bidder should save it and submit it online, without changing the filename. If the BoQ file is found to be modified by the bidder, the bid will be rejected.
8. The server time (which is displayed on the bidders’ dashboard) will be considered as the standard time for referencing the deadlines for submission of the bids by the bidders, opening of bids etc. The bidders should follow this time during bid submission.
9. All the documents being submitted by the bidders would be encrypted using PKI encryption techniques to ensure the secrecy of the data. The data entered cannot be viewed by unauthorized persons until the time of bid opening. The confidentiality of the bids is maintained using the secured Socket Layer 128 bit encryption technology. Data storage encryption of sensitive fields is done. Any bid document that is uploaded to the server is subjected to symmetric encryption using a system generated symmetric key. Further this key is subjected to asymmetric encryption using buyers/bid opener’s public keys. Overall, the uploaded tender documents become readable only after the tender opening by the authorized bid openers.
10. The uploaded tender documents become readable only after the tender opening by the authorized bid openers.
11. Upon the successful and timely submission of bids (i.e., after Clicking “Freeze Bid Submission” in the portal), the portal will give a successful bid submission message & a bid summary will be displayed with the bid no. and the date & time of submission of the bid with all other relevant details.
12. The bid summary has to be printed and kept as an acknowledgment of the submission of the bid. This acknowledgment may be used as an entry pass for any bid opening meetings.
13. **Code of Integrity for Public Procurement**
IUAC requires that the bidders, suppliers and contractors observe the highest standard of ethics during the

procurement and execution of such contracts. In pursuit of this policy, the following are defined:

Sr. No.	Term	Meaning
(a)	Corrupt practice	The offering, giving, receiving, or soliciting, directly or indirectly, of anything of value to influence the action of a public official in the procurement process or in contract execution.
(b)	Fraudulent practice	a misrepresentation or omission of facts in order to influence a procurement process or the execution of a contract.
(c)	Collusive practice	means a scheme or arrangement between two or more bidders, with or without the knowledge of the purchaser, designed to establish bid prices at artificial, non-competitive levels.
(d)	Coercive practice	means harming or threatening to harm, directly or indirectly, persons or their property to influence their participation in the procurement process or affect the execution of a contract.
(e)	Anti-competitive practice	any collusion, bid rigging or anti-competitive arrangement, or any other practice coming under the purview of the Competition Act, 2002, between two or more bidders, with or without the knowledge of the purchaser, that may impair the transparency, fairness and the progress of the procurement process or to establish bid prices at artificial, non-competitive levels
(f)	Conflict of interest	participation by a bidding firm or any of its affiliates that are either involved in the consultancy contract to which this procurement is linked; or if they are part of more than one bid in the procurement; or if the bidding firm or their personnel have relationships or financial or business transactions with any official of purchaser who are directly or indirectly related to tender or execution process of contract; or improper use of information obtained by the (prospective) bidder from the purchaser with an intent to gain unfair advantage in the procurement process or for personal gain
(g)	Obstructive Practice	materially impede the purchaser's investigation into allegations of one or more of the above mentioned prohibited practices either by deliberately destroying, falsifying, altering; or by concealing of evidence material to the investigation; or by making false statements to investigators and/or by threatening, harassing or intimidating any party to prevent it from disclosing its knowledge of matters relevant to the investigation or from pursuing the investigation; or by impeding the purchaser's Entity's rights of audit or access to information.

INSTRUCTIONS FOR ONLINE BID SUBMISSION

1. The tender documents are available on our website www.iuac.res.in & www.eprocure.gov.in.
2. Tender documents may be downloaded from IUAC's website www.iuac.res.in and CPPP site [http s://eprocure.gov.in/eprocure/app](http://s://eprocure.gov.in/eprocure/app) as per the schedule as given in the tender document.
3. Bids shall be submitted online only at CPPP website. Tenderers/ Contractors are advised to follow the instructions provided in the 'Instructions to the contractors/ Tenderer for the e-submission of the bids online through the Central Public Procurement Portal for e-procurement' at the CPPP website.
4. Not more than one tender shall be submitted by one contractor or contractors having business relationship. Under no circumstance will father and his son(s) or other close relations who have business relationship with one another (i.e. when one or more partner(s)/director(s) are common) be allowed to tender for the same contract as separate competitors. A breach of this condition will render the tenders of both parties liable to rejection.
5. The tender shall be submitted online in two parts, viz., Technical bid and Financial (price Bid) bid.
6. The offers submitted by hand/Post/Fax/email shall not be considered. No correspondence will be entertained in this matter.
7. The bidders are advised to visit CPPP website <https://eprocure.gov.in/eprocure/app> at least 3 days prior to closing date of submission of tender for any corrigendum / addendum/ amendment.

8. Bids will be opened as per date/time as mentioned in the **Tender Document**. After online opening and evaluation of technical bids, the results of their qualification as well Price-Bid opening will be intimated.
9. Submission of a tender by a tenderer implies that he has read all the stipulations contained in this tender document and has acquainted him of the nature, scope and specifications of the items to be followed.
10. The tenderer shall submit all documents after duly filling the same in all respects. Tenders which are found to be vague or incomplete shall be rejected summarily.
11. Tenders shall be submitted ON-LINE; it shall be signed by one who has been authorized by the board of director /director / manufacture/ firm owner /their authorized agents through a resolution/ authority letter. Copy of the resolution/ authority letter in favor of the person signing must accompany the tender.
12. Tenders containing erasures and alterations of the tender documents are liable to be rejected unless these are authenticated by the person signing the Tender Documents.

ASSISTANCE TO BIDDERS

1. More useful information for submitting online bids on the CPP Portal may be obtained at <https://eprocure.gov.in/eprocure/app>
2. Any queries relating to the tender document and the terms and conditions contained therein should be addressed to the Tender Inviting Authority for a tender or the relevant contact person indicated in the tender.
3. Any queries relating to the process of online bid submission or queries relating to CPP Portal in general may be directed to the 24x7 CPP Portal Help desk. The contact number for the help desk is 1800 3070 2232.

SPECIAL INSTRUCTIONS TO BIDDERS FOR REGISTRATION WITH COMPETENT AUTHORITY

Bidders Registration

1. Any bidder from a country which shares a land border with India will be eligible to bid in any procurement whether of goods, services (including consultancy services and non-consultancy services) or works (including turnkey projects) only if the bidder is registered with the Competent Authority constituted by the Department for Promotion of Industry and Internal Trade (DPIIT). Further, any bidder (including bidder from India) having specified Transfer of Technology (ToT) arrangement with an entity from a country which shares a land border with India, shall also be required to be registered with the same competent authority.
2. **“Bidder”** for the purpose of this tender (including) the term 'tender', 'consultant' 'vendor' or 'service provider' in certain contexts) means any person or firm or company, including any member of a consortium or joint venture (that is an association of several person, or firms or companies), every artificial juridical person not falling in any of the descriptions of bidders stated here in before, including any agency, branch or office controlled by such person, participating in a procurement process.
3. **“Bidder from a country which shares a land border with India”** for the purpose of this tender means:
 - a. An entity incorporated, established or registered in such a country; or
 - b. A subsidiary of an entity incorporated, established or registered in such a country; or
 - c. An entity substantially controlled through entities incorporated, established or registered in such a country; or
 - d. An entity whose beneficial owner is situated in such a country; or
 - e. An Indian (or other) agent of such an entity; or
 - f. A natural person who is a citizen of such a country; or
 - g. A consortium or joint venture where any member of the consortium or joint venture falls under any of the above
4. **“The Beneficial owner”** for the purpose of (3) above will be as under:
 - a. In case of a company or Limited Liability Partnership, the beneficial owner is the natural person(s), who, whether acting alone or together, or through one or more juridical person(s), has a controlling ownership interest or who exercises control through other means.

Explanation: -

 - I) “Controlling ownership interest” means ownership of, or entitlement to, more than twenty-five per cent of shares or capital or profits of the company;
 - II) “Control” shall include the right to appoint the majority of the directors or to control the management or policy decisions, including by virtue of their shareholding or management rights or shareholders agreements or voting agreements;
 - b. In case of a partnership firm, the beneficial owner is the natural person(s) who, whether acting alone or together, or through one or more juridical person, has ownership of entitlement to more than fifteen percent of capital or profits of the partnership;
 - c. In case of an unincorporated association or body of individuals, the beneficial owner is the natural person(s), who, whether acting alone or together, or through one or more juridical person, has ownership of or entitlement to more than fifteen percent of the property or capital or profits of such association or body of individuals;
 - d. Where no natural person is identified under (i) or (ii) or (iii) above, the beneficial owner is the relevant natural person who holds the position of senior managing official;
 - e. In case of a trust, the identification of beneficial owner(s) shall include identification of the author of the trust, the trustee, the beneficiaries with fifteen percent or more interest or more interest in the trust and any other natural person exercising ultimate effective control over the trust through a chain of control or ownership.

5. “An Agent” for the purpose of this Order is a person employed to do any act for another, or to represent another in dealings with third persons.

Sub-contracting in works contracts

In works contracts, including turnkey contracts, contractors shall not be allowed to sub-contract works to any contractor from a country which shares a land border with India unless such contractor is registered with the Competent Authority.

***Please note that the bidders shall provide the mandatory Certificates in the following formats on their registered Company's letter heads:**

Certificate for Tenders involving procurement

“I/We have read the clause regarding restrictions on procurement from a bidder of a country which shares a land border with India; I/we certify that we are not from such a country or, if from such a country, have been registered with the Competent Authority, I/we hereby certify that we fulfill all requirements in this regard and are eligible to be considered. [Where applicable, evidence of valid registration by the Competent Authority shall be attached]”

Certificate for Tenders for Works involving possibility of subcontracting

“I/We have read the clause regarding restrictions of procurement from a bidder of a country which shares a land border with India and on sub-contracting to contractors from such countries; I/we certify that we are not from such a country or, if from such a country, have been registered with the Competent Authority and will not sub-contract any work to a contracting from such countries unless such contractor is registered with the Competent Authority. I/we hereby certify that we fulfill all requirements in this regard and is/are eligible to be considered. [Where applicable, evidence of valid registration by the competent Authority shall be attached.]”

Certificate by Bidders in the cases of specified TOT

“I have read the clause regarding restrictions on procurement from a bidder having Transfer of Technology (ToT) arrangement. I certify that this bidder does not have any ToT arrangement requiring registration with the competent authority.”

OR

“I have read the clause regarding restrictions on procurement from a bidder having Transfer of Technology (ToT) arrangement. I certify that this bidder has valid registration to participate in this procurement.”

Tenderer’s Signature and seal

E - TENDER DOCUMENT

Name of Work / Supply	as per Annexure-A
Tender Number	IUAC/NIT/23/SGK/2023-24
Tender Value / Estimate only	INR 8 lakh/- (estimate only)
Earnest Money Deposit	INR 16000/- (2% of the tender value)
Tender Document Fee	NIL
Bid Submission End Date and Time (Part - A and Part - B)	12/02/2024 at 3:00 p.m.
Online Payment of EMD	https://services.sabpaisa.in/pages/iuac.html
Technical Bid Opening Date (Part - A)	13/02/2024 at 3:00 p.m.
Price Bid Opening Date (Part - B)	To be intimated later on to the technically qualified bidders
Mandatory Minimum Local Content	1) 50% for Class I Supplier 2) 20% for Class II Supplier
Margin of Purchase Preference for Local Content	20% (Pl. refer to the DPIIT Order mentioned at T& No.15)
Contact Person	Administrative Officer (S&P)/ Kumar, Scientist-F, HCI Group (For Technical clarifications) E-mail: iuacstores@gmail.com / E-mail: sugamkumar@gmail.com (For Technical clarifications) Phone: 011-24126018, 24126022.

General Terms and Conditions of the Tender

1. Submission of Tender:

Tenders should be uploaded on CPP Portal in two parts, i.e., Technical Bid (Part - A) and Price Bid / BOQ (Part – B).

2. Scope of work: “Dual Channel Low Noise High Voltage Fast Switch as per Annexure A” ..

3. Technical Bid (Part - A) :

Prequalification of the bidder:

- a. Only Original Equipment Manufacturer (OEM) or their authorized (sales and service) representatives are eligible to quote. The authorized representatives shall have to submit the certificate of authorization from the OEM along with the BID.
- b. The bidder must be a reputed firm/company/manufacture or their representative of vacuum related diagnostic components, who has supplied similar type of component to the reputed research laboratories in India or abroad.

Documents:

In this bid, the bidder should upload the following documents:

1. Tender Acceptance Letter (written on company letter head, duly signed and stamped.) as per format provide in **Annexure B**, as a token of acceptance of the NIT conditions, with this bid.
2. Profile of the Tenderer as per **Annexure C**
3. Earnest Money Deposit proof of submission, if applicable
4. Authorized Distribution Certificate with authorization from the OEM/ undertaking on letter head about authorized distributorship for the tendered items in India.
5. The quoted items should be a part of standard catalogue product /OEM website.
6. Purchase order copies of similar items (using motorized linear drives with encoders in vacuum) supplied in reputed laboratories / institutes in India / abroad during the last five (05) years of either of the following:
 - a. One purchase order of value not less than INR 6.4 lakhs. (80% of the estimated unit cost)
 - b. Two purchase order, each order value not less than INR 4 lakhs. (50% of the estimated unit cost)
 - c. Three purchase order, each order value not less than INR 3.2 lakhs (40% of the estimated unit cost)
7. Drawings / test results/catalogues/other technical specifications of the products, supplied so far, indicating its ability to meet the technical specifications.
8. Copies of previous three financial years (2020-21, 2021-22 & 2022-2023) Income Tax Return (ITR).
9. Average annual turnover during the last three financial years ending 31st March, 2023 [2020-21 & 2021-22, 2022-23] shall be at least Rs. 10 lakhs. Duly audited financial statement/balance sheet/certified by CA to be submitted as supporting documents.
10. Code of Integrity and conflict of interest as per **Annexure-D**.
11. Self- attested copies of GST registration and PAN number.
12. Declaration of local content as per **Annexure-E**.
13. Compliance form duly filled confirming the technical and service requirements of the product (**Annexure -F**).

14. The bidder should not be blacklisted by any Government, or Government Department, whether in the Central/State/District levels across India. An undertaking in this regard as per **Annexure-H** to be enclosed with the Technical Bid.
15. Check- list as per **Annexure-I**.

Technical bids which are not confirming to the technical specifications will be disqualified.

4. Price Bid / BOQ (Part - B) :

In this bid, the bidder is required to quote unconditional rates in the .XLS BOQ format provided with this tender. Quotes in INR will be accepted only. The Indigenous suppliers quoting in INR should quote the rates all-inclusive up to IUAC and excluding GST. IUAC is exempted from Customs Duty and GST and necessarily certificates shall be issued by IUAC along with the PO. The BOQ file must not be modified.

5. Earnest Money Deposit:

Bidder has to select the payment option as “online” to pay the EMD as applicable by going to the link <https://services.sabpaisa.in/pages/iuac.html> . The Earnest Money Deposit shall be in the form of online payment and it should be deposited before the bid opening. Bid Security shall be refunded to the un-successful bidders on award of contract and to successful bidders on receipt of Performance Security as per T&C point no. 8 below.

EMD is the mandatory requirement however the MSMEs/NSIC registered with Government Agencies are exempted from payment of Earnest Money Deposit (EMD) subject to conditions given below: -

- i) MSMEs participating in the tender must submit valid & authorized copy of certificate of registration. The MSME’s Bidder to note and ensure that nature of services and goods/items manufactured mentioned in MSME’s certificate matches with the nature of the services and goods/items to be supplied as per Tender.
- ii) The registration certificate issued by agencies must be valid as on Bid closing date of the tender. Bidder shall ensure validity of registration certificate in case bid closing date is extended.
- iii) The MSMEs who have applied for registration or renewal of registration with any of the authorised agencies / bodies, but have not obtained the valid certificate as on close date of the tender, are not eligible for exemption / preference.

6. Validity of Tender:

Tender shall be valid for our acceptance without any change in the rates and NIT conditions for a period of 90 days from the date of opening of price bid. No escalation of cost will be acceptable in any condition after opening of tender. No tenderer on his own withdraws or revokes the tender or revises or alters or modifies the tender for any item or condition within a period of aforesaid period.

7. Escalation / Deviation:

No escalation or deviation shall be allowed till execution of order / contract.

8. Performance Security:

The supplier shall require to submit the Performance Security within 15 days on issue of LOI in the form of irrevocable bank guarantee or FDR issued by any Indian Nationalized Bank for an amount which is 10% of the contract value and should be kept valid for a period of 60 days beyond the date of contractual obligations of the supplier including warranty/ defect liability obligations. The Performance Security shall be refunded to the supplier after the due certification by IUAC personnel.

9. Terms of Payment:

100% payment shall be made after final acceptance, as per the required specification, of all the goods at IUAC. The payment process will be initiated on submission of the bills by the bidder and after due certification by the concerned IUAC personnel. All payments will be made after statutory deductions.

10. Bid Opening and Evaluation of Bids

Opening of Bids

- a. The E-bids shall be opened on-line. The technical bids will be evaluated to shortlist the eligible bidders. The technical bids of only eligible bidders shall be considered for further processing (technical evaluation).
- b. Bidder whose technical bid is found to be acceptable and meeting the eligibility requirements as specified in this tender will be considered as technically qualified.
- c. IUAC will open commercial bids of only the technically qualified/short-listed bids.
- d. In case, the day of bid opening is declared a holiday by the government, the E-bids will be opened on the next working day at the same time. No separate intimation shall be sent to the bidders in this regard
- e. Since E-bid is an on-line process, the E-bid opening or any other process may be delayed due to any technical/server issue. If any such issue arises, this will not be tantamount to process delay and IUAC will not be responsible for the same.
- f. On opening of bids on-line, accepting the bid would not mean that the firm is technically or financially qualified.

10.1 Clarification of Bids and shortfall documents

- (a) During the evaluation of Techno commercial or Financial Bids, Indentor on behalf of IUAC may, at its discretion, but without any obligation to do so, ask Bidder to clarify its bid by a specified date. Bidder should answer the clarification within that specified date (or, if not specified, 7 days from the date of receipt of such request). The request for clarification shall be submitted in writing or electronically and no change in prices or substance of the bid shall be sought, offered or permitted that may grant any undue advantage to such bidder.
- (b) IUAC reserves its right to, but without any obligation to do so, to seek any shortfall information / documents only in case of historical documents which pre-existed at the time of the tender opening, and which have not undergone changes since then and does not grant any undue advantage to any bidder.

11. Guarantee/Defect liability period:

The supplied material should be guaranteed from manufacturing / engineering defect and bad material / workmanship for a **minimum period of one year** from the date of acceptance of the goods by IUAC. During this period if any replacement/ repairs/ rectification of any of the supplied item etc. is needed, the supplier shall do the same free of cost to IUAC. If the equipment/ part needs to be shipped to the service centre for repair/rectification during the guarantee period, the shipment charges should be borne by the supplier. The supplier shall guarantee that all equipment shall work satisfactorily and that the performance and efficiency of the equipment shall not be less than the specified values. The bidder shall assure the supply of spare parts after warranty is over for maintenance of the equipment supplied if and when required for a period of at least two years.

12. Timeline for supply:

All the goods should be supplied at IUAC within **40 days** from the date of issue of Purchase order. Any delay in completion of the work/supply due to reasons attributable to the vendor / manufacturer is liable to liquidated damages as per clause 12 of this NIT. However, under the force-majeure conditions as per clause 13 of NIT, IUAC may grant suitable time extension for which vendor has to request along with the justification / reasons well in advance to the Director, IUAC for approval without any prejudice or price escalation.

13. Liquidated damages:

In case the delivery of the listed items is delayed beyond the specified delivery period for reasons attributable to the supplier, deductions on account of liquidated damages @ 0.5% per week subject to maximum of 10 % of the total order value will be deducted.

14. Force Majeure:

IUAC may grant an extension of time limit set for the supply items in case it is delayed by force majeure beyond the supplier's control. Force majeure is defined an event of effect that cannot reasonably be anticipated such as acts of God (like earthquakes, floods, tsunami etc.), the direct and indirect consequences of wars (declared or undeclared), national emergencies, pandemics/epidemics, civil commotions and strikes (only those which exceeds a duration of ten continuous days) at successful Tenderer's factory. Apart from the extension of the time limit, force majeure does not entitle the successful tenderer to any relaxation or to any compensation of damage or loss suffered. The decision of the Director, IUAC will be final and binding for the bidder.

15. Preference to Make in India:

Preference to local suppliers shall be given as per revised Public Procurement (Preference to Make in India), Order 2017, No. P-45021/2/2017-PP (B.EII) dated 16.09.2020 and order no. P-45021/102/2019-BE- II- Part (1) (E-50310) dated 04.03.2021, issued by DPIIT, Ministry of Commerce and Industry, Govt. of India as notified from time to time. (Submit duly filled Declaration of Content, Annexure-F for the same). The Declaration of Content once submitted in the Technical Bid will be final. Submission of Revised Declaration of Content will NOT be accepted. Bidders are requested to refer the above-mentioned orders for details.

16. Final Acceptance:

The final acceptance of the system is defined as successful completion of shipment and acceptance at IUAC to substantiate compliance with the specification mentioned in Annexure A. The representative of the vendor is required to demonstrate functionality to required specifications of each item at IUAC after receipt of the goods within one month. Vendor should provide operation and technical manual and calibration chart along with the supplied goods.

17. Termination for Insolvency

IUAC may at any time terminate the Contract by giving written notice to the Supplier, if the Supplier becomes bankrupt or otherwise insolvent. In this event, termination will be without compensation to the Supplier, provided that such termination will not prejudice or affect any right of action or remedy, which has accrued or will accrue thereafter to the Purchaser.

18. Indemnity

The Supplier shall indemnify, protect and save IUAC against all claims, losses, costs,

damages, expenses, action suits and other proceeding, resulting from infringement of any law pertaining to patent, trademarks, copyrights etc. or such other statutory infringements in respect of all the equipment's supplied by him.

19. Negotiation

Normally, there shall not be any negotiation. Negotiations, if at all, shall be an exception and only in the case of items with limited source of supply and where there are possibilities of getting cartel formation. Negotiations shall be held with the lowest evaluated responsive bidder only.

20. Tender Rejection:

Director, IUAC reserves the right to accept/reject any/all tenders in part/full without assigning any reason whatsoever and the decision of the IUAC in this regard will be binding on all the bidders.

- a. Bids received by means other than e - procurement portal will be rejected.
- b. Only complete bids will be considered and incomplete bids will be rejected.
- c. If BOQ file is found to be modified by the bidder, the bid will be rejected. Only INR quote will be acceptable.
- d. Tenders not complying with any of the provisions stated in this tender document are liable to be rejected.
- e. If the General Terms and conditions are not accepted and not signed by the bidders, then the tender will be rejected.
- f. Tender will be rejected on non-submission of 'Bid Security Declaration'.

21. The contract shall be governed by the Indian Laws. Any dispute arising out of this contract will be subjected to jurisdiction of New Delhi / Delhi only.

22. Correspondence:

All the correspondence in respect of tender / contractual obligation/ technical shall be made to The Administrative Officer (S&P) / (For technical clarifications) Dr. Sugam Kumar, Scientist-F, Inter University Accelerator Centre, Aruna Asaf Ali Marg, New Delhi-110067. E-mail: iuacstores@gmail.com, sugamkumar@gmail.com. Phone: +91-11-24126018, 24126022.

This notice inviting tender will form part of the contract agreement to be executed by the successful tenderer.

Accepted
(Signature of Bidder)

SPECIAL TERMS AND CONDITIONS OF CONTRACT

1.0 Carrying of work

All the work shall be carried out in accordance strictly as per the specifications given in the tender to the total satisfaction of the Institute.

2.0 Contractors/Supplier Responsibility for the manner of Execution of Work

The contractor/supplier shall be solely responsible for the manner and the method of executing the work. The work shall be subject to the approval of IUAC from time to time for purposes of determination of the question whether the work is executed by the contractor in accordance with the contract.

3.0 Specifications

During execution of work, the contractor/bidder should follow all standard norms of safety measures/precautions as per relevant codes to avoid accidents/damages to man, machines and buildings, at his own cost. If specifications for an item of work are not covered as per approved Specifications of tender, the same shall be decided by the Institute and shall be binding on the contractor.

4.0 Agency's Risk

All risks of loss of a or damage to physical property and of personal injury and death which arise during and in consequence of the performance of the contract other than the excepted risks are the responsibility of the contractor /supplier.

5.0 Action and Compensation payable in case of Bad work

5.1 If it shall appear to IUAC, or our representatives, that any work has been executed with unsound, imperfect or unskillful workmanship then the contractor/supplier shall be liable to pay compensation.

5.2 If during the execution of works, any damage is caused to IUAC property by contractor's/supplier's workers, contractor/supplier will duly make good the loss. IUAC has the right to make suitable deduction from contractor's/supplier's bills along with penalty, if contractor/supplier fails to make good the loss.

5.3 No material belonging to the contractor/supplier whether consumable or non-consumable should be brought inside the IUAC campus without proper entry at the Main Gate nor any material should be taken out without proper gate pass issued by the authorized representatives of the Centre. Goods delivery challans duly entered at the main gate shall to be submitted. It shall always prevail, unless otherwise specifically stated, that the entire provisions of Tender document been opened upon and accepted for compliance by the contractor/supplier without any reservation.

5.4 If during the execution of works, any damage is caused to IUAC property by contractor's/supplier's workers, contractor/supplier will duly make good the loss. IUAC has the right to make suitable deduction from contractor's bills along with penalty, if contractor/supplier fails to make good the loss.

6.0 During execution of work, the contractor/supplier should follow all standard norms of safety measures/precautions as per relevant codes to avoid accidents/damages to man, machines and buildings, at his own cost. Contractor/supplier will have his own arrangement to escort the labour to the nearest hospital for treatment in case any injury happens to any worker during execution of work.

Seal & Signature of Bidder/Bidder

Annexure – A

Introduction

The tender is floated to procure **Dual channel of low noise, fast switching, high voltage type independent switches** for beam line deflector applications. The switches must be of demonstrated for its stability, precision and very low noise with actual load conditions having followed the standard mounting layouts.

The leads of switches must be able to withstand and must be capable of switching positive and negative high voltages upto 200 Volts without any damage to the switches. Unlike a DC power switch, there will be a capacitive load at the output but very little current of less than milli ampere. The output must be optimized for high stability, precision and very low noise. The outputs should be completely free of parasitic switching spikes in the RF region.

The switches shall be mounted in a 19” box. The heat generated within unit must be vented as per industry standard. Spare components suggested components for next 2 to 5 years.

Schematic of the high voltage switch: The inputs A and B can be connected to an appropriate high voltage supply. The output will be connected to capacitive load. Nominal loads from 0pF to 300pF can be connected. Standard 5V / 0V signal applied to this control input. During experiment a PC controlled Delay-Gate generator or function generator will be connected here. In general, both input voltages may reside in the range between -200V and +200V versus GND, but their difference should not exceed 200V.

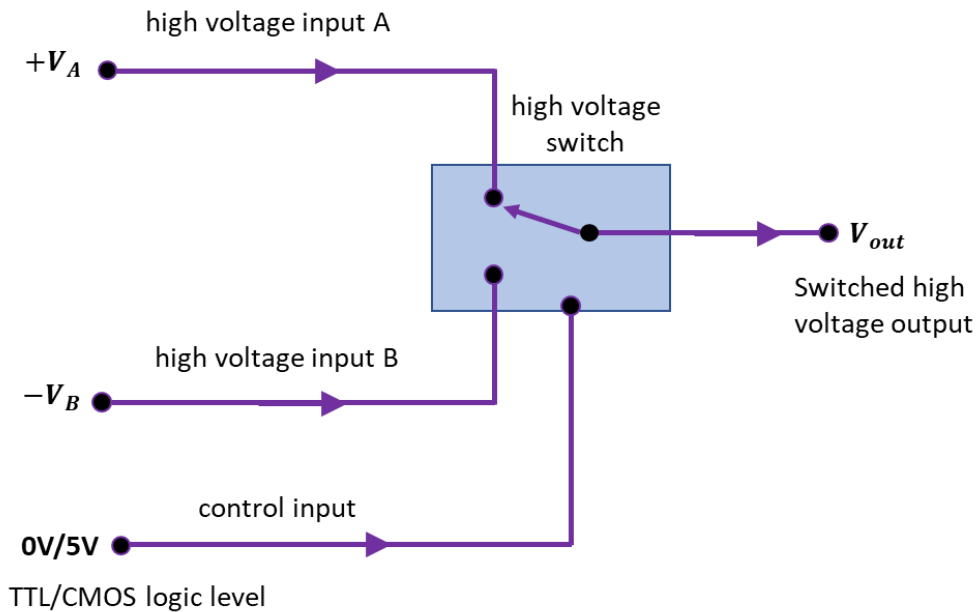

Figure 1: Schematic of the high voltage fast switch

The specification of the switch is listed in the following table.

Table 1: Technical specifications:

Specifications	Values	Requirement
Number of channels	2	Dual channel switch, two switches must be completely independent
Output voltage span	200V	Output voltages of maximum 200V span
Voltage difference between A to B	200V	Input A always needs to be on more positive potential with respect to B
Input A or B vs. GND	+/- 200V	Both polarities may be applied vs. GND
Output rise and fall time (10% to 90% of voltage step size)	<50ns	<20pF load capacitance
	<150ns	<250pF load capacitance
Delay jitter	<0.5ns rms	Output voltages of maximum 200V span
Noise	<150 μ Vrms	Better than or equal to 150 μ Vrms
Intrinsic switch capacitance on OUT terminal	<100pF	
Maximum pulse duration	Infinite	
Minimum pulse duration	<7 μ s	
Input/output voltage Connector	SHV/BNC	
Case Dimensions	19 inch wide	19-inch rack-mount case
Control Input		
Compatibility	TTL/ C-MOS compatible	A digital TTL/CMOS signal level 0V/5V
Signal level	0V and 5V	
Drive rate / switching rate	0 to 2kHz	Switch should support switching rates up to 2kHz
Power Supply	230 VAC at 50Hz	The power entry module should be EMI/RFI-filtered
Control input connector	BNC	

Note: Supply of similar or same item supplied to similar laboratory applications recently with contact reference.

The unit must fulfil at least one of these EMC/EMI regulatory directives of IEC / FCC / European.

Annexure B
TENDER ACCEPTANCE LETTER
(To be given on Company Letter Head)

Date:

To,
The Director
IUAC, New Delhi-67

Sub: Acceptance of Terms & Conditions of Tender.

Tender Reference No: IUAC/NIT/.....

Name of Tender / Work: -

Dear Sir,

I/ We have downloaded / read and examined the tender document(s) for the above-mentioned Tender /Work from the web site(s) namely:

as per your advertisement, given in the above-mentioned website(s).

1. I / We hereby certify that I / we have read the entire terms and conditions of the tender documents (including all documents like annexure(s), schedule(s), etc .), which form part of the contract agreement and I / we shall abide hereby by the terms / conditions / clauses contained therein.
2. The corrigendum(s) issued from time to time by your department/ organization too have also been taken into consideration, while submitting this acceptance letter.
3. I / We hereby unconditionally accept the tender conditions of above-mentioned tender document(s) / corrigendum(s) in its totality / entirety.
4. I / We do hereby declare that our Firm has not been blacklisted/ debarred by any Govt. Department/Public sector undertaking.
5. I / We certify that all information furnished by our Firm is true & correct and in the event that the information is found to be incorrect/untrue or found violated, then your department/ organization shall without giving any notice or reason therefore or summarily reject the bid or terminate the contract, without prejudice to any other rights or remedy.

Yours Faithfully,

(Signature of the Bidder, with Official Seal)

Annexure-C
PROFILE OF THE TENDERER
(To be given on Company Letter Head)

**TENDER FOR SUPPLY OF UHV Compatible Double slit assembly with
controller as per Annexure A**

1.	Name of the Firm / organization	
2.	Address	
3.	Telephone No. / Mobile No. & Name of the Contact Person	
4.	Fax No.	
5.	E-mail ID	
6.	Month and Year of establishment	
7.	Name of proprietor / partners/director	
8.	No. of years of experience in this field, with Reference, Certificates	
9.	Average annual financial turnover during the last three financial years ending 31 st March, 2023. Duly audited financial statement/balance sheet/certified by CA to be submitted as supporting documents. 2020-21: 2021-22: 2022-23:	
10.	Whether the firm is a Tax Assessee? If so, please give the details of PAN No. and copies of ITR files for the last three financial years	
11.	GST Registration No.	
12.	Name of the OEM and address	

Signature of the Tenderer & Seal

ANNEXURE-D
Format for declaration by the Bidder for Code of Integrity & conflict of interest
(On the Letter Head of the Bidder)

No: _____

Date _____

To,
The Director IUAC
New Delhi

Sir,

With reference to your Tender No. _____ dated _____ I/We hereby declare that we shall abide by the Code of Integrity for Public Procurement as in your Tender document and have no conflict of interest.

It is certified that we are not associated, or have been associated in the past, directly or indirectly, with a firm or any of its affiliates which have been engaged by the Purchaser to provide consulting services for the preparation of the design, specifications, and other documents to be used for the procurement of the goods to be purchased under this Invitation of Bids / Tender.

The details of any previous transgressions of the code of integrity with any entity in any country during the last three years or of being debarred by any other Procuring Entity are as under:

- a
- b
- c

We undertake that we shall be liable for any punitive action in case of transgression/ contravention of this code.

Thanking you,

Yours sincerely,

Signature
(Name of the Authorized
Signatory)

Company Seal

ANNEXURE-E
DECLARATION OF LOCAL CONTENT

(To be given on Company Letter Head – For tender value below Rs.10 Crores)
(To be given by Statutory Auditor/ Cost Auditor/ Cost Accountant/ CA for tender value above Rs.10 Crores)

To,
The Director,
Inter University Accelerator Centre
Aruna Asaf Ali Marg
New Delhi- 110 067

Subject: - Declaration of Local Content

Tender Reference No : _____

Name of Tender/ Work: _____

1. Country of Origin of Goods being offered: _____

2. We hereby declare that items offered has _____% local content

3. Details of the Location at which the Local Value Addition is made _____

4. Details of Local Content

“Local Content” means the amount of value added in India which shall, unless otherwise prescribed by the Nodal Ministry, be the total value of the item procured (excluding net domestic indirect taxes) minus the value of the imported content in the item (including all customs duties) as a proportion of the total value, in percent.

Bidders offering Imported products will fall under the category of Non-Local Suppliers. They cannot claim themselves as Class-I or Class –II Local Suppliers by claiming the services such as Transportation, Insurance, Installation, Commissioning, Training and After Sale Service Support like AMC/ CMC etc. as Local Value Addition.

“*False declaration will be in breach of Code of Integrity under Rule 175(1)(i)(h) of the General Financial Rules for which a bidder or its successors can be debarred for up to two years as per Rule 151(iii) of the General Financial Rules along with such other actions as may be permissible under law.”

Yours faithfully,

(Signature of the bidder, with Official Seal)

Note: Preference shall be given to local suppliers as per revised Public Procurement (Preference to Make in India), Order 2017, No. P-45021/2/2017-PP (B.E-II) dated 16.09.2020 issued by DPIIT, Ministry of Commerce and Industry, Govt. of India. (Submit duly filled Declaration of Local Content for the same). The Declaration once submitted in the Technical Bid will be final. Submission of Revised Declaration will NOT be accepted.

ANNEXURE - F (COMPLIANCE SHEET)
Compliance Sheet for quoted items

S. No.	Part Description	Quantity
1	Dual Switch Low Noise High Voltage Switch	1

<u>Technical Specifications</u>	<u>Compliance (YES/ NO)</u>
Dual channel switch, two switches is completely independent	
Output voltages of maximum 200V span	
At input A and B, the maximum voltage Span is 200V.	
Both polarities may be applied vs. GND	
Input A always needs to be on more positive potential with respect to B.	
Output rise and fall time (10% to 90% of voltage step size) <50ns and <150ns for <20pF load capacitance and <250pF load capacitance respectively	
Delay jitter is <0.5ns rms	
Each output exhibits a very low broadband noise (DC to 20MHz) of smaller than 150µVrms	
Intrinsic switch capacitance on OUT terminal is <100pF	
Maximum pulse duration is infinite and minimum pulse duration is less than <7µs	
Switching rates up to 2kHz is supported	
Input/output voltage Connector type SHV/BNC	
A digital TTL/CMOS control signal level 0V/5V	
Control input connector of BNC type	
The power entry module should be EMI/RFI-filtered	
Case dimension of the switch is 19" rack-mount	
Spare components available for next 2 to 5 years.	
The leads of switches must be able to withstand and must be capable of switching positive and negative high voltages upto 200 Volts without any damage to the switches.	
The heat generated within unit must be vented as per industry standard	
Supply of similar or same item supplied to similar laboratory applications recently with contact reference.	
The unit must fulfil at least one of these EMC/EMI regulatory directives of IEC / FCC / European.	

Signature of Bidder with official seal

Annexure -H

(Undertaking to be given on Bidders/ Company Letter Head)

I / We (bidder) hereby give an undertaking that:

1. I / We have not been blacklisted / on holiday list / debarred during last three years by any Govt. Department/Govt. Autonomous Body/Institution, etc.
2. I/We do not have any dispute with any of the Govt. Departments/ Govt. Autonomous Bodies/Institutions, etc.
3. I/We have never been certified as 'Unsatisfactory Performer' for the said services provided to the Govt. Departments/ Govt. Autonomous Bodies/ Institutions;
4. I/We have not submitted any fake/forged certificates/ documents and later, if any such 'Certificates/Documents' found to be fake/ forged or contains willful wrong/incorrect information, suitable legal actions may be initiated against me/us/agency and the agencies/ bidders shall be debarred from tendering with the Institute.
5. I/We shall not withdraw my/our bid after opening of Technical Bid and if done so, the IUAC and the agencies / bidders shall be debarred from tendering with the Institute.

Seal and Signatures of the Authorized
Person of the Agency

Name and designation of the
Authorized Person of the Agency

Place:

Date:

Annexure-I

CHECK-LIST FOR PRE-QUALIFICATION BID FOR: UHV Double slit assembly with controller as per Annexure A

IUAC, Aruna Asaf Ali Marg, New Delhi-110067

Sr. No.	Documents Provided	Page number
1.	Certificate - Bidder Not from/ from Country sharing Land border with India & Registration of Bidder with Competent Authority (<i>on company's letter head</i>) (Refer to the special instructions to bidders for registration with competent authority)	
2.	Tender Acceptance Letter (Annexure-B)	
3.	Profile of the tenderer (Annexure-C)	
4.	OEM Authorization Certificate and Manufacturer's Authorization form	
5.	Technical Specification , Datasheet, Drawings, Catalogue etc.	
6.	Copies of purchase orders as specified in the NIT	
7.	Copies of ITR filed for the last three financial years	
8.	Declaration for Code of Integrity and Conflict of Interest (Annexure-D)	
9.	Self-attested copy of the GSTIN & PAN card issued by the respective authorities.	
10.	Declaration of local content (Annexure-E)	
11.	Compliance Sheet for quoted items (Annexure-F)	
12.	Performance Demo undertaking (Annexure-G)	
13.	Undertaking on a letter head along with tender document. (Annexure-H)	
14.	Copy of MSME/NSIC Registration Certificate	
15.	Copies of Average annual financial turnover during the last three financial years ending 31st March, 2023[2020-21, 2021-22 & 2022-23] . Duly audited financial statement/balance sheet/certified by CA to be submitted as supporting documents.	
16.	EMD proof of submission	
17.	Any other documents	

(Seal & Signatures of Bidder)

(Name and Address of the Bidder)